

# EP1501 Intelligent Controller

with Paired Reader Interface for One Physical Barrier

This device complies with part 15 of the FCC Rules. Operation is subject to the following two conditions: (1) This device may not cause harmful interference, and (2) this device must accept any interference received, including interference that may cause undesired operation.

Installation and Specifications:

## 1. General:

The EP1501 intelligent controller provides decision making, event reporting, and database storage for the Mercury hardware platform. Two reader interfaces configured as paired or alternate readers provide control for one door.

Host communication is via the on-board 10-BaseT/100Base-TX Ethernet port.

**Note:** For UL installations, POE powered devices shall not be used, power for these devices must be provided by an UL 294 listed power limited source (12Vdc).

One physical barrier can be controlled with the EP1501, using single or paired readers. The first reader port can accommodate a read head that utilizes Wiegand, magnetic stripe, or 2-wire RS-485 electrical signaling standards, one or two wire LED controls, and buzzer control (one wire LED mode only). This port can also utilize multiple RS-485 multi-dropped devices.

The second reader port can accommodate a read head that utilizes Wiegand or magnetic stripe signaling, one or two wire LED controls, and buzzer control (one wire LED mode only). Two form-C relay outputs may be used for strike control or alarm signaling. The relay contacts are rated at 2A @ 30Vdc, dry contact configuration. Two inputs are provided for monitoring the door contact, exit push button or alarm contact. The EP1501 requires 12Vdc for power or Power over Ethernet (PoE). The EP1501 may be mounted in a 3-gang switch box; a mounting plate is supplied with the unit. The EP1501 may be mounted in an enclosure; the supplied mounting plate has mounting holes that match the MR50 mounting footprint.

## 2. EP1501 Hardware:

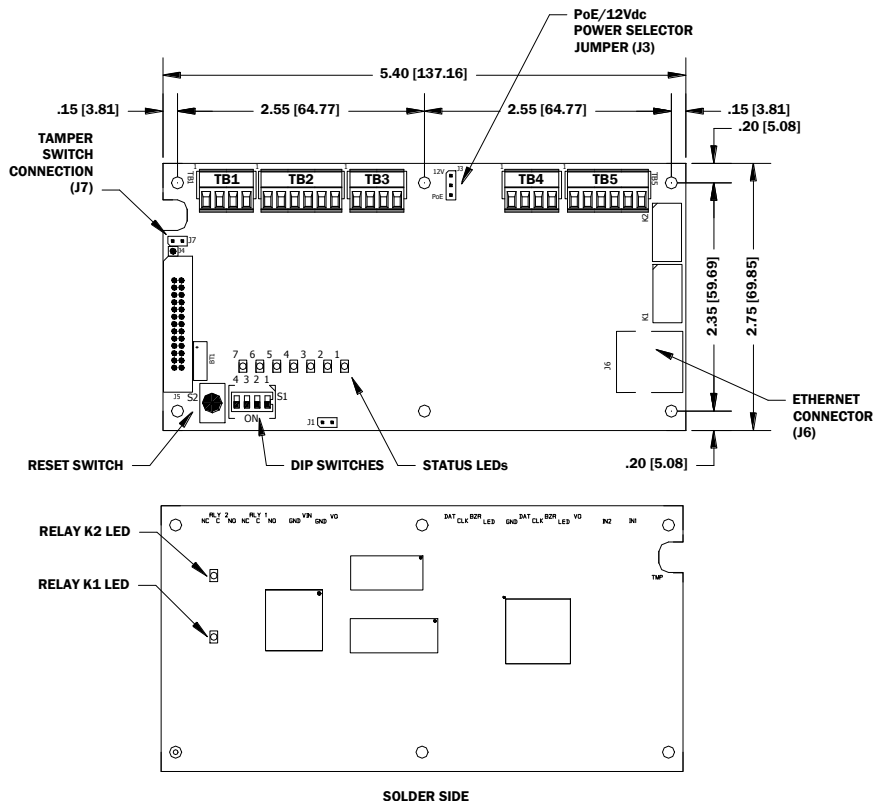

Information Subject to Change Without Notice PRELIMINARY

### 3. EP1501 Wiring and Setup:

EP1501 CONNECTIONS		
TB1-1	IN1	Input 1
TB1-2	IN1	
TB1-3	IN2	Input 2
TB1-4	IN2	
TB2-1	VO	Reader 1 Power Output – 12VDC
TB2-2	LED	Reader 1 LED Output
TB2-3	BZR	Reader 1 Buzzer Output
TB2-4	CLK	Reader 1 CLK/Data 1/TR+
TB2-5	DAT	Reader 1 DAT/Data 0/TR-
TB2-6	GND	Reader 1 Ground
TB3-1	LED	Reader 2 LED Output
TB3-2	BZR	Reader 2 Buzzer Output
TB3-3	CLK	Reader 2 CLK/Data 1 Input
TB3-4	DAT	Reader 2 DAT/Data 0 Input
TB4-1	VO	Auxiliary Power Output – 12Vdc
TB4-2	GND	Auxiliary Power Output Ground
TB4-3	VIN	Input Power – 12Vdc (from local power supply)
TB4-4	GND	Input Power Ground
TB5-1	NO	Relay K1 – Normally Open Contact
TB5-2	1-C	Relay K1 – Common Contact
TB5-3	NC	Relay K1 – Normally Closed Contact
TB5-4	NO	Relay K2 – Normally Open Contact
TB5-5	2-C	Relay K2 – Common Contact
TB5-6	NC	Relay K2 – Normally Closed Contact

Jumpers:

JUMPERS	SET AT	DESCRIPTION
J1	N/A	Factory Use Only
J2	N/A	Factory Use Only (A,B, & C pads)
J3	PoE	EP1501 powered from the Ethernet connection
	12V	EP1501 powered from an external 12Vdc power source connected to TB4-3 (VIN), TB4-4 (GND)
J4	N/A	Factory Use Only
J5	N/A	Factory Use Only
J6	N/A	10Base-T/100Base-Tx Ethernet Connection (Port 0)
J7		Cabinet Tamper: normally open switch

### DIP Switches:

The four switches on S1 DIP switch configure the operating mode of the EP1501 processor. DIP switches are read on power-up except where noted. Pressing switch S2 causes the EP1501 to reset.

1	2	3	4	Definitions
OFF	OFF	X	OFF	Normal operating mode.
ON	X	X	X	After initialization, enable default User Name (admin) and Password (password). The switch is read on the fly, no need to re-boot.
OFF	ON	X	OFF	Use factory default communication parameters.
ON	ON	X	OFF	Use OEM default communication parameters. Contact system manufacture for details. See Bulk Erase below.
X	X	ON	X	Disable TLS secure link. Switch is read only when logging on.

All other switch settings for unassigned and are reserved for future use.

### Factory Default Communication Parameters:

Network: static IP address: 192.168.0.251

Communication address: 0

Host port: IP server, no encryption, port 3001.

### Bulk Erase Configuration Memory:

Use the bulk erase function to erase all configuration and cardholder databases. When power is applied with S1 switches set to 1 & 2 ON and 3 & 4 OFF, there is a 10-second window that if switch 1 or 2 is changed to the OFF position memory is erased. The LEDs flash the following pattern when in the reset window: LED 1 & 2 and LED 3 & 4 flash alternately at .5 second rate. When erasing memory, LED 2 flashes at a 2 second rate; **DO NOT CYCLE POWER**. It takes less than 60 seconds to erase the memory. LEDs 1 and 4 flash for 10 seconds after the memory has been erased, then the EP1501 will re-boot.

## 4. Input Power:

The EP1501 is powered by one of two ways (jumper selected, J3):

- Power is supplied via the Ethernet connection using PoE, fully compliant to IEEE 802.3af
- Or local 12Vdc power supply, TB5-3 (VIN), TB5-4 (GND).

## 5. Communication Wiring:

The EP1501 controller communicates to the host via the on-board 10-BaseT/100Base-TX Ethernet interface (port 0).

## 6. Reader Wiring:

The first reader port supports Wiegand, magnetic stripe, and 2-wire RS-485 electrical interfaces. The second reader port supports Wiegand magnetic stripe electrical interfaces. Power to the first reader is 12Vdc and is current limited to 150mA. The second reader may be powered from the auxiliary power output on TB4-1 and TB4-2. Readers that require different voltage or have high current requirements should be powered separately. Refer to the reader manufacture specifications for cabling requirements. In the 2-wire LED mode, the Buzzer output is used to drive the second LED. Reader port configuration is set via the host software.

The first reader port can support multiple multi-dropped RS-485 devices. If this configuration is used, the second reader port will not support a third reader.

### Reader Wiring Diagram:

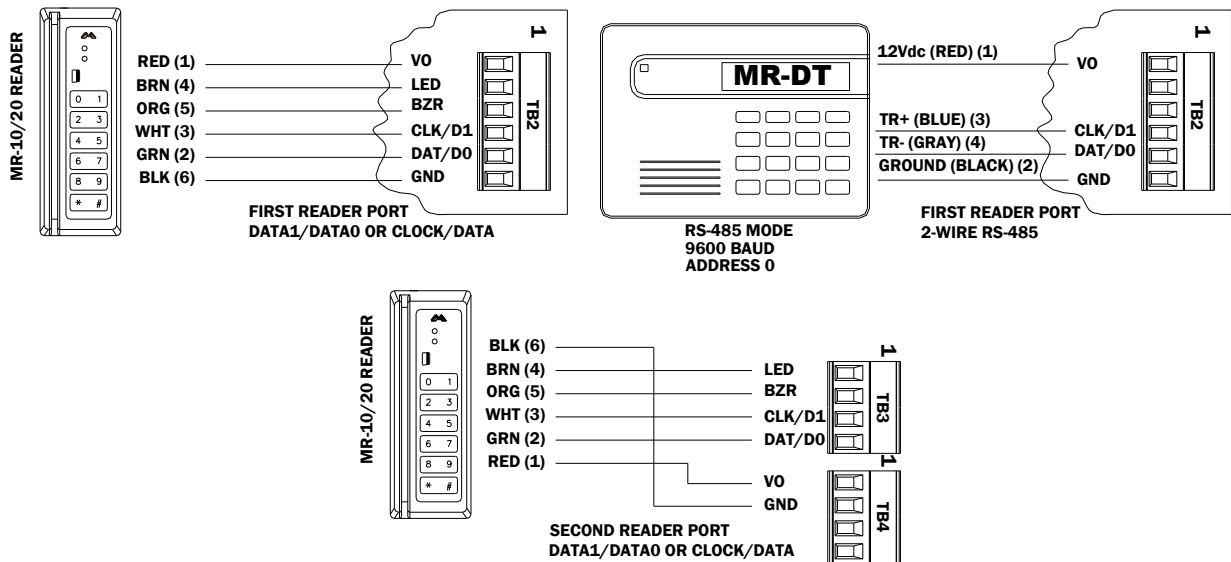

## 7. Input Circuit Wiring:

Typically, these inputs are used to monitor door position, request to exit, or alarm contacts. Input circuits can be configured as unsupervised or supervised. When unsupervised, reporting consists of only the open or closed states.

When configured as supervised, the input circuit will report not only open and closed, but also open circuit, shorted, grounded\*, and foreign voltage\*. A supervised input circuit requires two resistors be added to the circuit to facilitate proper reporting. The standard supervised circuit requires 1K Ohm, 1% resistors and should be located as close to the sensor as possible. Custom end of line (EOL) resistances may be configured via the host software.

\* Grounded and foreign voltage states are not a requirement of UL 294 and therefore not verified by UL.

The input circuit wiring configurations shown are supported but may not be typical:

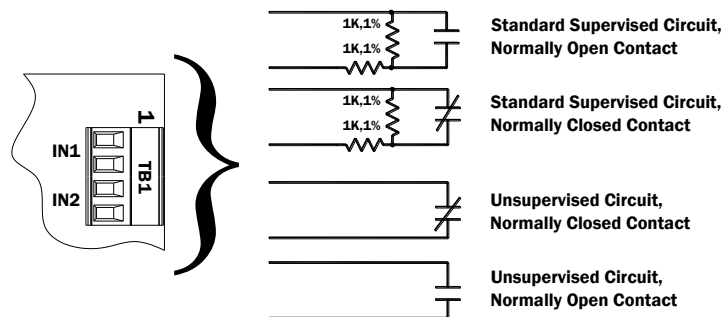

## 8. Relay Circuit Wiring:

Two relays are provided for controlling door lock mechanisms or alarm signaling. The relay contacts are rated at 2A @ 30Vdc, dry contact configuration. Each relay has a Common pole (C), a Normally Open pole (NO) and a Normally Closed pole (NC). When you are controlling the delivery of power to the door strike, the Normally Open and Common poles are used. When you are momentarily removing power to unlock the door, as with a mag lock, the Normally Closed and Common poles are used. Check with local building codes for proper egress door installation.

Door lock mechanisms can generate feedback to the relay circuit that can cause damage and premature failure of the relay. For this reason, it is recommended that either a diode or MOV (metal oxide varistor) be used to protect the relay. Wire should be of sufficient gauge to avoid voltage loss.

## Relay Circuit Wiring Diagram:

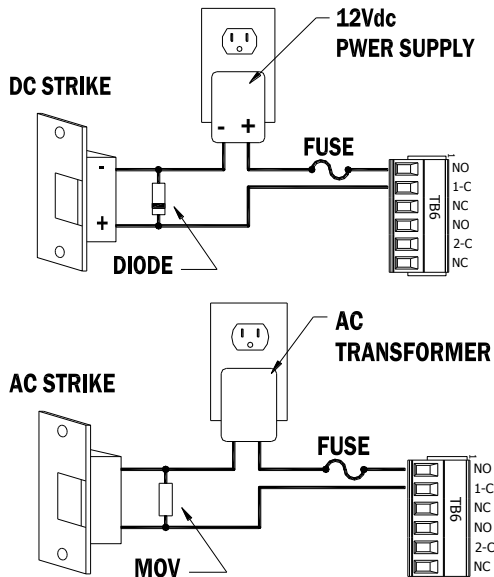

Diode Selection:  
 Diode current rating: 1x strike count  
 Diode breakdown voltage: 4x strike voltage  
 For 12Vdc or 24Vdc strike, diode 1N4002  
 (100V/1A) typical.

MOV Selection:  
 Clamp voltage: 1.5x Vac RMS.  
 For 24Vac strike, Panasonic ERZ-C07DK470  
 typical

## 9. Memory Backup Battery:

The SRAM is backed up by a rechargeable battery when input power is removed. This battery should retain the data for about 2 weeks. If data in the SRAM is determined to be corrupt after power up, all data, including flash memory, is considered invalid and is erased. All configuration data must be re-downloaded. **Note:** The initial charge of the battery may take up to 24 hours to be fully charged.

## 10. Status LEDs:

**Power-up:** All LED's OFF.

**Initialization:** LED's 1, 2, 3, 4, 5, 6, and 7 are sequenced during initialization. LED's 1, 3, and 4 are turned ON for approximately 4 seconds after the hardware initialization has completed, then the application code is initialized. The amount of time the application takes to initialize depends on the size of the database, about 3 seconds without a card database. Each 10,000 cards will add about 3 seconds to the application initialization. When LED's 1, 2, 3 and 4 flash at the same time, data is being read from or written to flash memory, do not cycle power when in this state.

If the sequence stops or repeats, perform the Bulk Erase Configuration Memory procedure in DIP switch note in section 2. If clearing the memory does not correct the initialization problem, contact technical support.

**Running:** After initialization is complete, the LEDs have the following meanings: At power up, LEDs 2 through 7 are turned ON then OFF in sequence.

LED	DESCRIPTION
1	Off-Line / On-Line and Battery Status
	Off-Line = 20% ON, On-Line = 80% ON
	Double Flash if Battery is Low
2	Host Communication Activity
3	Readers (Combined) Reader 1: Clock/Data or D1/D0 Mode = Flashes when Data is Received, Either Input. RS-485 Mode = Flashes when Transmitting Data
4	Input IN1 Status: OFF = Inactive, ON = Active, Flash = Trouble
5	Input IN2 Status: OFF = Inactive, ON = Active, Flash = Trouble
6	Cabinet Tamper
7	Not used
YEL	Ethernet Speed: OFF = 10Mb/S, ON = 100Mb/S
GRN	OFF = No Link, ON = Good Link, Flashing = Ethernet Activity

## 11. Specifications:

The interface is for use in low voltage, class 2 circuits only.

The installation of this device must comply with all local fire and electrical codes.

Power Input: PoE Power Input 12.95W, compliant to IEEE 802.3af  
 – OR –  
 12Vdc  $\pm$ 10%, 200mA minimum, 900mA maximum

Power Output: 12Vdc @ 650mA including reader and AUX output

**Note:** For UL installations, POE powered devices shall not be used, power for these devices must be provided by an UL 294 listed source (12Vdc).

SRAM Backup Battery: Rechargeable battery.

Host Communication: Ethernet: 10BaseT/100Base-TX

Inputs: 2 supervised, Programmable End of Line resistors, 1k/2k – ohm, 1% 1/4W watt standard, and dedicated tamper input.

Relays: 2 outputs, Form-C contacts: 2A @ 30Vdc.

### Reader Interface:

Reader Power: PoE: 12 Vdc $\pm$ 10% or local power supply (12Vdc). (PTC limited 150mA max)

Reader Data Inputs: Two TTL reader ports or one 2-wire RS-485 reader port capable of supporting two readers.

RS-485 Mode: 9600 bps, asynchronous, half-duplex, 1 start bit, 8 data bits, and 1 stop bit. Maximum cable length: 4000' (1,200m).

LED Output: TTL compatible, high > 3V, low < 0.5V, 5mA source/sink maximum.

Buzzer Output: Open collector, 5Vdc open circuit maximum, 10mA sink maximum.

### Cable requirements:

Power: 1 twisted pair, 18 AWG

Ethernet: CAT-5 (minimum)

RS-485: 24AWG, 4,000ft (1,200m) maximum, twisted pair(s) with an overall shield.

Alarm Input: 1 twisted pair per input, 30-ohm maximum loop resistance.

Reader data (TTL): 18AWG, 6 conductors, 500-foot (150 m) maximum

Reader data (RS-485): 24AWG, 120-ohm impedance, twisted pair with shield, 4000-foot (1,219 m) maximum

### Environmental:

Temperature: 0 to 70°C, operating, -55 to +85°C, storage

Humidity: 10 to 95% RHNC

### Mechanical:

Dimension: 5.5" (140mm)W x 2.75" (70mm)L x 0.96" (24mm)H without bracket  
 5.5" (140mm)W x 3.63" (92mm)L x 1.33" (34mm)H with bracket

Weight: 3.8 oz. (106.35g) without bracket  
 4.7 oz. (133.28g) with bracket

## 12. Additional Mounting Information:

Sources for the optional items shown below:

- 3-gang stainless steel blank cover: Leviton part number 84033-40. Available from Graybar, part number 88158404
- Magnetic switch set: G.R.I. part number: 505

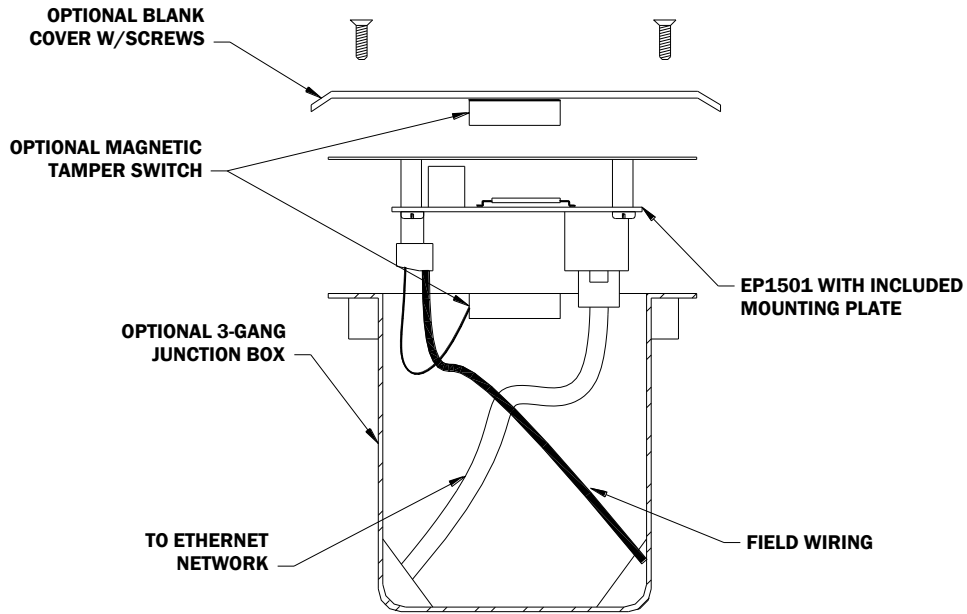

### Mounting Plate Dimensions:

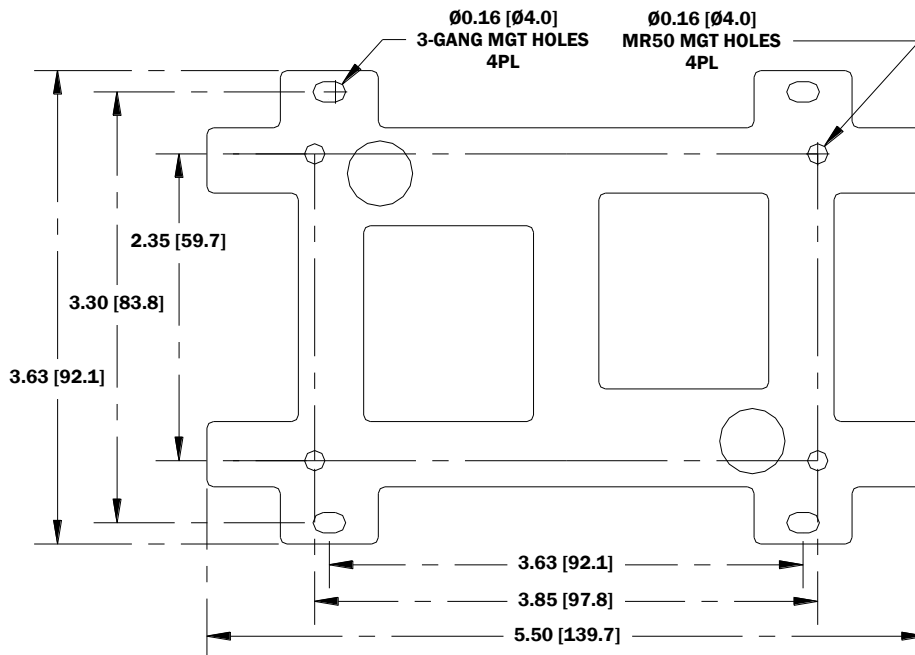

Information Subject to Change Without Notice PRELIMINARY

## **Warranty**

Mercury Security Corporation warrants the product is free from defects in material and workmanship under normal use and service with proper maintenance for one year from the date of factory shipment. Mercury Security Corporation assumes no responsibility for products damaged by improper handling or installation. This warranty is limited to the repair or replacement of the defective unit.

There are no expressed warranties other than set forth herein. Mercury Security Corporation does not make, nor intends, nor does it authorize any agent or representative to make any other warranties, or implied warranties, and expressly excludes and disclaims all implied warranties of merchantability or fitness for a particular purpose.

Returned units are repaired or replaced from a stock of reconditioned units. Returns must be accompanied by a return authorization number (RMA) obtained from customer service, and prepaid postage and insurance.

## **Liability**

The Interface should only be used to control exits from areas where an alternative method for exit is available. This product is not intended for, nor is rated for operation in life-critical control applications. Mercury Security Corporation is not liable under any circumstances for loss or damage caused by or partially caused by the misapplication or malfunction of the product. Mercury Security Corporation's liability does not extend beyond the purchase price of the product.